

Congratulations!

Enjoy your now complete shelving unit.

seville classics®

UltraDurable® Commercial-Grade NSF 4-Tier Steel Wire Shelving

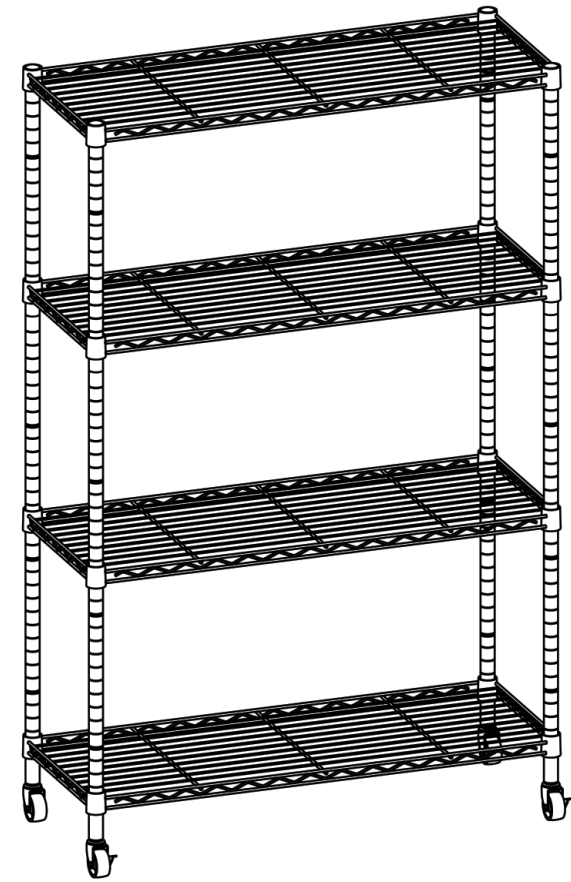

Caution

- Place heavier items on the lower shelves and lighter ones on the top.
- Do not stand or climb on the shelving system.
- Do not drop heavy items on the system.
- Do not move the system while loaded.

Specifications

Dimensions: 36" W x 14" D x 56.5" H

Weight capacity	Per shelf	Overall
On leveling feet	300 lbs. (136 kg.)	1200 lbs. (544.3 kg.)
On wheels	82.5 lbs. (37.4 kg.)	330 lbs. (150 kg.)

Customer Service Information



Telephone: (800) 323-5565
Fax: (310) 533-3899
Hours: 8:30 AM – 4:30 PM (PST)
Email: Support@SevilleClassics.com
Homepage: www.SevilleClassics.com

Model #: SHE15380B/ SHE15381B/ SHE15385B/ SHE15387B

Thank you for choosing Seville Classics! We hope that you enjoy your steel wire shelving! Please read through this guide for parts list, assembly instructions, frequently asked questions and further contact information.

Parts List

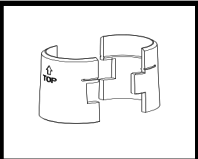
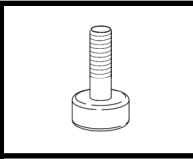
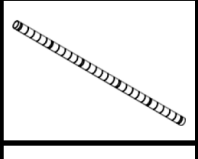
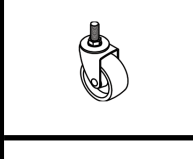
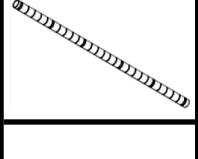
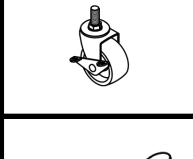
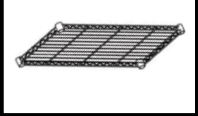
Please make sure you have all the parts on this list.

A. Slip Sleeves (16)		E. Feet (4)	
B. Bottom Poles (4)		F. Wheels (2)	
C. Top Poles (4)		G. Locking wheels (2)	
D. Shelves (4)		H. Wrench (1)	

If you're missing parts, contact us for replacements at (800) 323-5565 or send an email to Support@SevilleClassics.com

Assembly Instructions

STEP 1.

Screw **WHEELS (F)** and **LOCKING WHEELS (G)** into base of bottom poles with **WRENCH (H)**. Or, screw in **LEVELING FEET (E)**. Repeat for all bottom poles.

STEP 2.

Snap **SLIP SLEEVES (A)** around the grooves on **BOTTOM POLES (B)** for your lowest shelf.

TIP! Count the number of grooves from the bottom of the pole to keep the height consistent.



STEP 3.

Fit **SHELF (D)** over the top of the 4 poles and over **SLIP SLEEVES (A)**.

Repeat **STEPS 2-3** for remaining shelves.

TIP! If necessary, lightly tap shelves into place with a rubber mallet.

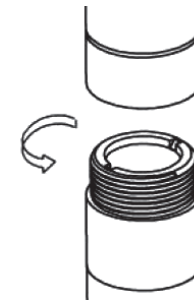

STEP 4.

Screw **TOP POLES (C)** into the tops of the **BOTTOM POLES (B)**.

STEP 5.

Repeat **STEPS 2-3** for remaining shelves.

